

LAB PROJECT 1000-08A

I-DEAS

NAME: _____

DATE: _____

The purpose of Lab Project 1000-08 is to become acquainted with a CAD program

Read the Log-In, the SDRC I-DEAS project and the Log-out procedure in its entirety, prior to arriving at the computer lab, rooms R-140 or R-155 on South Campus.

Use the attached Lab Open Times sheet to find out when the lab is available.

Follow the instructions given throughout this lab project to finally save the project on the computer's hard drive. If you have any problems, ask for help from one of the instructors (Jim Carlson, Tom Kirelli, Lisa Richter, or Marty Sirowatka) or one of the students working in the lab.

LOG_IN Procedure:

1. On the first log-in screen, enter the ID, IN LOWER CASE: **egr100xx** (type in lower case letters)
2. Enter the password: **mcc**
3. Write down the computer number you are using: _____
4. Write down the last four digits of your social security number: _____
5. Open a terminal window by clicking on the arrow located ABOVE the text editor icon on the lower tool bar.
6. Type **ideas** in the terminal window, then press **Enter**.
7. The first time you start the software, the computer may ask you to define which display device you are using. Simply hit **Enter** when the question appears. If any additional help windows, netscape windows or file windows appear, click on the minus sign in the upper left corner of the window; then choose exit to get rid of the window.
8. When the I-DEAS Start menu appears, select **egr100xx** and then enter the file name for your project:

Use the following file name to save your project: **engr_XX_###**

Where XX is the first letter and last number of your course's section number and ##### are the last four digits of your social security number. Example: **engr_C2_5012**

9. The Application should be set on "DESIGN" and the Task set on "MASTER MODELER."
10. Select "OK" from the lower left hand corner to create a new model file, then hit "OK" to enter the software.



11. Sketch the part.
 Select the Polyline icon from the icon panel by clicking on it once with your left (first) mouse button (MB1.) Notice that the prompt window located along the bottom of the screen is asking you to begin sketching. Sketch a shape similar to Figure 1, using your left mouse button (MB1) to start and your middle mouse button (MB2) to end the string. Be sure to end the sketch/string at the same point you began, insuring that you create a closed sketch.

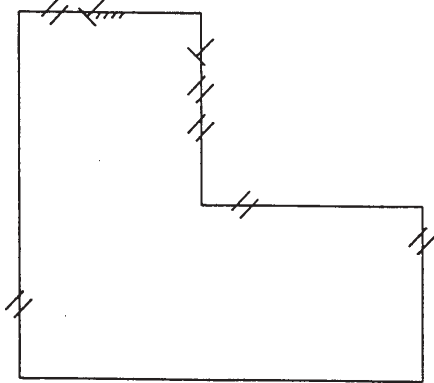

Figure 1



12. Dimension the sketch.
 Select the dimension icon and dimension the sketch as shown in Figure 2. The Dimension icon in I-DEAS requires that you select the two entities you wish to create a dimension between. Once the icon is selected, notice that the prompt window is asking you to select the first entity to dimension. Select a line by clicking on it once with your MB1. The prompt window will now prompt you to select the second entity to dimension., select the second line with MB1. Next you need to place the location of the text. To do this, move your mouse to the desired location and click once with MB1. Continue this process until your sketch has the dimensions Figure 2 has. Do not worry about the values of the dimensions.

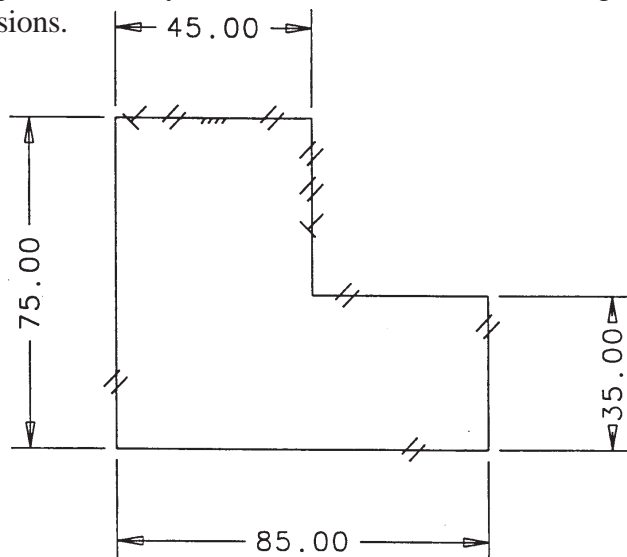
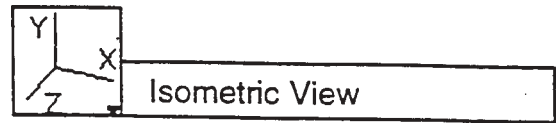

Figure 2

13. Change the View.

Next you will change the view from the XY Plane to an Isometric View. Select the Isometric icon by clicking on it once with your MB1.



14. Extrude the Sketch.

Next you will extrude your 2D sketch to create a solid model. Select the Extrude icon. The prompt window asks you to pick a curve or section. Using your MB1, click anywhere on the sketch you just created. The software will develop a bold, colored line along your sketch. This defines what wireframe will be used to create the model. To end the wireframe selection process, hit MB2. You will see a window appear. This is the extrude window where you can set the various parameters for extruding your part. Simply type over the default value in the distance box and enter a value of **125**. Next hit **OK** on the bottom left corner of the Extrude window with MB1. Your part should resemble the solid model in Figure 3.

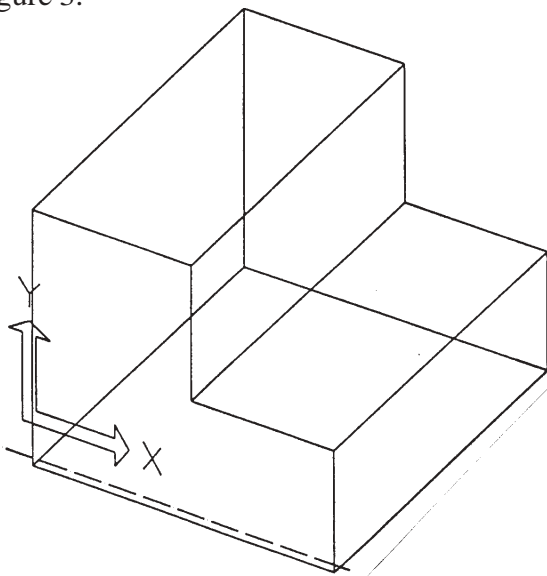
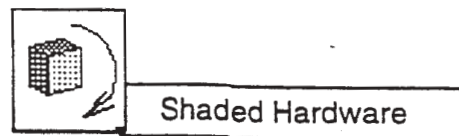
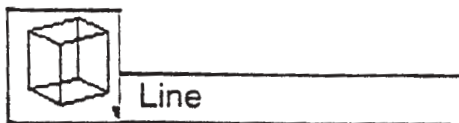

Figure 3

15. Shade the Part.

Lastly, you will shade the part. Select the Shaded Hardware icon. Your part should no longer be transparent. To return to the unshaded mode, select, with MB1, the Line icon located just left of the Shaded Hardware icon.



15. Save the Project

Before you log off, you will need to save your file. Simply select **File** and **Save** from the drop down menus along the top of the icon panel. The List window along the bottom of the screen (left of the Prompt window) should display the message that your model file has been saved.

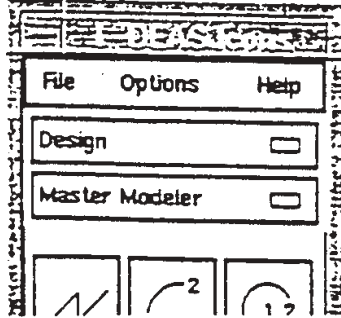

16. Log Off.

Exit the software by selecting **File** and **Exit** from the icon panel drop down menu.

Select the **EXIT** button from the lower tool bar, to exit the terminal.

Select **Continue Logout** in the pop-up window.

17. Turn in only the completed front sheet of this lab project, as soon as you have completed the project.

Once the instructor has checked your work on the computer hard drive, you will receive your grade.